



Installation Operation Maintenance

Flex Series



CG-SVX035A-GB
Original instructions

1. OVERVIEW	2
1.1 Warranty	2
1.2 Receiving the unit	2
1.3 Factory inspection.....	2
2. SAFETY REGULATIONS	3
2.1 Preamble	3
2.2 Definitions	3
2.3 Access to DANGEROUS AREAS.....	3
2.4 General precautions	3
2.5 Precautions against risks due to the refrigerant	3
2.6 Precautions against residual risks	4
2.7 Prevention against residual mechanical risks	4
2.8 Prevention against residual electrical risks	4
2.9 Prevention against residual risks of a different nature	5
2.10 Precautions to be observed during maintenance operations	5
2.11 Manual alarm reset.....	5
2.12 Operating range.....	6
The operating ranges are indicated on the plate placed on the unit	6
3. INSTALLATION.....	6
3.1 Moving and positioning the unit	6
4. CONTROL OF COMPRESSOR FASTENING.....	6
5. ELECTRICAL CONNECTIONS	6
5.1 Electrical power supply	6
5.2 Power connections	7
5.3 Unbalance between the supply tension phases	7
6. water connections for air-water and water-water units	7
6.1 Evaporator	7
6.2 Water circuit regulation equipment	7
6.3 HYDRAULIC DIAGRAM	7
7.1 Ducts connection for AIR – AIR units	7
7.2 Ducts connection to the indoor unit for AIR – AIR units	7
7.3 Condense drain connection for AIR – AIR units.....	8
8. START-UP PRELIMINARY PROCEDURES	10
8.1 Starting check	10
8.2 Refrigerant seals control.....	8
8.3 Refrigerant charge check	10
8.4 Refrigerant charge	10
9. START-UP	130
9.1 Preliminary controls	130
9.2 Starting up	130
9.3 Warm up of the plant for units air to water and water to water.....	15
9.4 Control of the oil charge	135
9.5 Power supply to the auxiliary circuit	145
10 MAINTENANCE	15
10 .1 SIGHT CHECK OF THE UNDER PRESSURE VESSELS STATE.....	16
11. RECOMMENDED SPARE PARTS	16
12. IMPROPER USES	17

1. OVERVIEW

Warranty

- A. Warranty is based on the general terms and conditions of the manufacturer. The warranty is void if the equipment is repaired or modified without the written approval of the manufacturer, if the operating limits are exceeded or if the control system or the electrical wiring is modified. Damage due to misuse, lack of maintenance or failure to comply with the manufacturer's instructions or recommendations is not covered by the warranty obligation. If the user does not conform to the rules of this manual, it may entail cancellation of warranty and liabilities by the manufacturer.
- B. Warranty is twelve (12) months as from the date of first start up at installation place or eighteen (18) months after delivery at the project or other delivery location indicated by the customer. The date the unit is operated for the first time means the date reported in the "1st start up form" contained into the "unit log book". This form should be filled in and sent, within 8 days from the start up, to Trane.
- C. The warranty is valid if all the installation and start-up instructions have been adhered to (both those which may have come from Trane and those coming from current practice), if the "1st start up form" has been filled in and sent to the Trane after sales department.
- D. The warranty is subject to any faults or defects being reported within eight days from their discovery. The warranty will only be applied if and when the purchaser suspends use of the equipment as soon as a defect has been found.
- E. The warranty is valid if the first running of the unit is carried out by a Trane authorized assistance center.
- F. The warranty is subject to regular maintenance of the unit which is appropriately indicated in the "unit log book" located inside the electrical panel.
- G. Warranty automatically ends in case of payments not fulfilled, non-performance of the contract and even if the units show tampering without TRANE written approvals.

Receiving the unit

On receiving the unit, it is up to the customer to check that there is no obvious damage or pieces missing. If this is so, an immediate complaint must be made to the carrier for damage or for not-delivery and the Receiving Card to be found inside the unit electrical panel must be filled in. Photographic evidence must be provided for macroscopic damage. The card must be sent to Trane within 8 days of receiving the goods: if it is not sent back or delayed, the complaint will not be accepted.

1.3 FACTORY INSPECTION

Trane units are inspected into the factory, in appropriate areas, in accordance with internal procedures. Each performance test carried out on the unit is possible only if the same conditions are reproduced and maintained (charge consistency, constant temperature and evaporation - condensation and recovery capacity, quality and tolerance of the measuring instruments etc.) in the test rooms.

The inspection conditions are those indicated by the customer in the ordering phase: if not otherwise specified, reference should be made to the nominal performance indicated in the technical bulletin in force at the date of the Confirmation of the Order.

2. SAFETY REGULATIONS

2.1 PREAMBLE

All Trane units are designed, built and inspected in compliance with the European Community Directives n° 98/37/CE (three phase power supply), EN 60335 Part 1 and 2, low voltage directive 73/23/CEE, electromagnetic compatibility directive EMC 89/336/CEE, Pressure Equipment Directive 97/23/CEE. Before using the machine read carefully the recommendations reported in the following manual.

2.2 DEFINITIONS

2.2.1 Owner:

The legal representative of the company, body or natural person who owns the plant in which the Trane unit is installed: he or she is responsible for the control and respect of all the safety regulations indicated in this manual as well as the national ones in force.

2.2.2 Installer:

The legal representative of the company appointed by the owner to position and hydraulically, electrically etc. connect the Trane unit to the plant: he or she is responsible for moving and the correct installation of the unit in accordance with the indications in this manual and with the national regulations in force.

2.2.3 Operator:

A person authorised by the owner to carry out all the operations of regulation and control on the Trane unit which are specifically mentioned in this manual. He or she should keep to actions described in the manual and limit his or her action to what is explicitly allowed.

2.2.4 Technician:

A person who is directly authorised by Trane or, secondarily, for all EU countries except for Italy, by the distributor of the Trane product, under their own responsibility, to carry out all ordinary or extraordinary maintenance operations, as well as regulations, controls, repairs and parts replacement which may be necessary during the lifetime of the unit.

2.3 ACCESS TO DANGEROUS AREAS

The access to the unit dangerous areas is usually obstructed through protection panels, which are removable, by using a tool. Axial fans are protected with accident prevention grilles. Centrifugal fans are not protected on the discharge, as they have to be connected to ducts. In case they have to run without ducts, it is the installer duty to provide protection grilles. Finned coil, for units not equipped with coil protection grilles, is completely accessible with danger for cuts and abrasions. In these cases technicians and operators must be aware about this risk.

For all the units which allow access to the cooling piping or to the packaged condensing coils with fins, without security gratings (optional) or closing panelling, the following precautions must be taken:

-mark the areas with contact risks.

-apply warning signs.

The danger zone must be of a suitable size to avoid any contact, even accidental contact.

In the presence of safety valves without relevant remote controls, the operating area must be of a size which considers a range of action of the discharge flow of 3 metres.

Trane declines any responsibility for damage to things and unauthorised personnel in case of absence of clear and static limiting systems of the risk areas and of the relevant warning and danger signs.

2.4 GENERAL PRECAUTIONS

The operator must only intervene on the unit commands; he or she must not open any panels except for the one which gives access to the command module.

The installer must only intervene on the connections between the plant and the machine; he or she must not open any machine panels nor carry out any commands.

The following precautions should be made when approaching or working on the unit:

- do not wear jewellery, baggy clothes or any other accessory which can get caught up.
- Use appropriate protection (gloves, glasses etc.) when using an open flame (welding) or compressed air.
- If the unit is located in a closed environment, wear hearing protection.
- before disconnecting, removing tubes, filters, joints or other line parts intercept the connection tubes, empty them until the pressure reaches that of the atmosphere.
- do not use your hands to check for possible pressure losses.
- always use tools which are in good condition; make sure the instructions have been fully understood before using them.
- make sure that any tools, electrical cables or other loose objects have been removed before closing the unit and starting it up again.

2.5 PRECAUTIONS AGAINST RISKS DUE TO THE REFRIGERANT

Safety data	R407 - R134a - R410a
Toxicity	Not important
Risks for skin touching	Splashes or sprinkles can cause chill burns. The risk of absorptions through the skin is not relevant.
	Those refrigerants could take some lightly irritating effects and in liquid stage they have a strong skinning effect. In this case it is necessary to rinse with fresh water the contaminated parts of the skin
	The refrigerant in liquid stage in contact with wet fabrics cause freezing and adherence to the skin. In this case it is necessary to put off the contaminated clothes to avoid freezing. Please contact a doctor in case of irritation of the contaminated parts.
Risks for contact with the eyes	Vapors don't take any effect. Splashes or sprinklers can cause chill burns. In those cases it is necessary to rinse the eyes with water or with solution for ocular washings for 10 minutes. The intervention of a doctor is needed.
Risks for ingestion	Should it happen, it causes chill burns. It does not cause vomiting. The person must be kept awake. It is needed to rinse the mouth with fresh water and to drink almost 0,25 liters. The intervention of a doctor is needed.
Risks for inhalation	High concentration of vapours in air can lead to anaesthetic effects up to a loss of conscience. Long exposures could give rise to cardiac arrhythmia and sometimes even to death.

	High concentrations can create a reduction of oxygen in air, with consequent possibility of suffocation. Should it happen the person must be taken to the open air and let him to take a rest. Administer oxygen if needed. In case the breathing has interrupted or become irregular, it is necessary to apply the artificial breathing. In case of cardiac arrest a heart massage must be applied. Contact a doctor immediately.
Conditions to avoid	Use in presence of exposed flames, and of elevates levels of humidity.
Dangerous reactions	Possibility of violent reactions with the sodium, the potassium, the barium and with other alkaline substances, incompatible materials and all the alloys containing more than 2% of magnesium.
Protection wearing - Behavior in case of losses or escapes	Wear protection apparel and self respirators. Insulate the source of the loss, if this operation can be done in safety conditions. Small quantitative of refrigerant escaped at liquid state can be allowed to evaporate only if the room is well ventilated. In case of great losses ventilate the room immediately. Plug the loss with sand, soil or other absorbent material; avoid that the liquid refrigerant can enter in water-drainages or losing pools.
Dismantlement	The best procedure is the recovery and the recycle. If this is not possible the refrigerant must be conferred to an accredited system for its destruction in order to neutralize acid and toxic by-products.

2.6 PRECAUTIONS AGAINST RESIDUAL RISKS

Prevention from risks due to the command system

- make sure the instructions for use have been understood before carrying out any work on the control panel.
- always keep the instruction manual close at hand when working on the control panel.
- start up the unit only after having certified that it is correctly connected to the plant.
- inform the technician promptly of any alarms which appear on the unit.
- do not reset the alarms to manual restart without having first identified the cause and removed it.

2.7 PREVENTION AGAINST RESIDUAL MECHANICAL RISKS

- install the unit in accordance with the provisions of the following manual.
- carry out all the maintenance operations provided for by this manual regularly.
- wear a protective helmet before entering inside the unit.
- before opening a machine panel make sure that it is firmly connected by means of a hinge.
- do not touch the air condensation batteries without having first put on protective gloves.
- do not remove the protections to the moving parts while the unit is running.
- before restarting the unit make sure that the moving part protections are in the correct position.

2.8 PREVENTION AGAINST RESIDUAL ELECTRICAL RISKS

- connect the unit to the mains in accordance with the provisions of this manual.
- carry out all maintenance operations regularly.
- before opening the control panel disconnect the unit from the mains by means of the external knife switch.
- check that the unit has been earthen correctly before starting it up.
- control all the electrical connections, the connection cables paying particular attention to the state of isolation; replace the cables which are clearly worn or damaged.
- carry out periodic checks of the wiring inside the panel.
- do not use cables with an inappropriate section or flying connections not even for a limited period or in an emergency.

2.9 PREVENTION AGAINST RESIDUAL RISKS OF A DIFFERENT NATURE

- The residual risk due to pressure are mainly coming from non functioning of the safety devices. To prevent them it is necessary to follow the checks and replacements as following indicated (§12.1 and 13)
- To protect from safety devices exhausting it is not allowed to remove the protections while the unit is in operation and to approach the unit without wearing the right protections. In case of accidental contact with refrigerant due to the safety valves exhaust it is necessary to follow the above indicated (§2.5)
- carry out the plant connections to the unit by following the indications reported on the following manual and on the panels of the unit itself.
- if a part is disassembled, make sure that it is correctly reassembled before restarting the unit.
- do not touch the discharge line of the compressor, the compressor itself or any other tube or component which is inside the machine without putting on protective gloves.
- keep a fire extinguisher which is able to put out fires on electrical equipment near the machine.
- on units installed inside, connect the refrigerant circuit shut off valve to a network of tubes which are able to lead the possible spillage of refrigerating fluid outside.
- eliminate any fluid loss inside or outside the unit.
- collect the discharge liquid and clean up any possible oil leakage.
- periodically clean the compressor casing of the accumulated dirt deposits.
- do not keep inflammable liquids near the unit.
- do not dispose of the refrigerant fluid and the lubricating oil in the environment.
- welding should only be carried out on empty tubes; do not approach the tubes containing refrigerant fluid with flames or other sources of heat.
- do not bend or strike tubes containing pressurised fluids.

2.10 PRECAUTIONS TO BE OBSERVED DURING MAINTENANCE OPERATIONS

Authorised technicians may only carry out maintenance operations.

Before carrying out any maintenance the following must be performed:

- isolate the unit from the mains electricity by using the external knife switch.
- place a notice on the external knife switch which says “**do not use - maintenance in progress**”.
- make sure that any possible on-off commands are disabled.
- use appropriate safety equipment (helmet, isolating gloves, protective glasses, safety shoes etc.).

If measurements or controls must be carried out which require the machine to be running the following observations must be followed:

- operate with the electrical panel open for as short a time as is possible.
- close the electrical panel as soon as the individual measurement or control has been carried out.
- for units which are located outside, do not carry out interventions in dangerous atmospheric conditions such as rain, snow, fog etc.

The following precautions should also be taken at all times:

- never dispose of fluids contained in the refrigerant circuit into the environment.
- when replacing an EPROM or electronic card always use appropriate equipment (extractor, anti static bracelet, etc.).
- if a compressor, the evaporator, the condensation batteries or any other heavy part is to be replaced, make sure that the lifting equipment matches the weight to be lifted.
- in the air cooled units with an independent compressor compartment, do not open the ventilator compartment without having first isolated the machine using the knife switch on the side of the panel and only after having placed a sign which says “do not use - maintenance in progress”.
- if modifications must be carried out to the cooling, hydraulic or electrical circuit of the unit, as well as to its command logic, contact Trane.
- if particularly complicated assembly or disassembly operations are to be carried out contact Trane.
- always use original spare parts bought directly from Trane or from official dealers of the companies reported in the list of recommended spare parts.
- if the unit is to be moved after a year of being in the site or if it has to be dismantled contact Trane.

2.11 MANUAL ALARM RESET

If there is an alarm the unit must not be manually reset before having located and eliminated the cause of the fault. Repeated manual resets may cause the guarantee to be annulled.

2.12 OPERATING RANGE

The operating ranges are indicated on the plate placed on the unit

3. INSTALLATION

3.1 MOVING AND POSITIONING THE UNIT

The units have been designed to be lifted from above by means of eyebolts and holes in the base members.

Use retractor bars to keep the lifting wires or chains away from the unit.

Lifting procedures provided with the unit have to be respected.

Attention

Do not use forklift trucks to lift the unit from below.

If equipment for lifting from above is not available, using rollers may move the unit.

The surface on which the unit is placed must be flat and strong enough to withstand the weight of the unit while running.

In order to reduce the transmission of vibrations to the supporting structures, fit shock absorbers in every fastening point.

Rubber shock absorbers are recommended for units installed on the ground, spring shock absorbers for units installed on roofs. Open spaces around the unit must be provided for in order to allow for the passage of necessary airflow and in order to allow normal maintenance to be carried out (as shown on general catalogues).

ATTENTION: in case two units have to be installed side by side, the distance of respect must be doubled.

After the unit has reached the final position, fix the antivibration bolts.

3.2 PRECAUTIONS FOR DOMINANT WINDS

Avoid obstacles on suction and discharge sides of the units. Respect the safety distances as shown on the units dimensional drawings.

In case of presence of dominant winds in the installation area it is strictly necessary to avoid (for units with horizontal flow fans) that such winds blow in front of the unit (fans discharge side). In case of unit with vertical flow fans it is strictly necessary to avoid installations where the dominant winds could cause rejected hot air to come back to the condensing coils.

4. CONTROL OF COMPRESSOR FASTENING

The compressors are fitted on shock absorbers. For fixing through spring antivibration mounts, it is necessary to remove blockages put to fasten the compressors, as indicated on the label on compressors body.

5. ELECTRICAL CONNECTIONS

5.1 ELECTRICAL POWER SUPPLY

The mains power supply characteristics have to match the unit's absorption. The mains power supply tension must correspond to the nominal value $\pm 10\%$, with a maximum difference between the phases of 3%.

5.2 POWER CONNECTIONS

Protect the unit electric box power supply circuit with protection devices (not included in the supplied equipment) Connect the line terminals with a three-core cable of a section, which is appropriate to the machine absorption. The switch and the fuses like all the power connections must comply with the regulations in force.

5.3 UNBALANCE BETWEEN THE SUPPLY TENSION PHASES

Do not run the electrical motors when the voltage unbalance between the phases is more than 3%. Use the following formula to check:

$$\% \text{ Voltage unbalancement} = \frac{\text{Max voltage deviation from average}}{\text{voltage average}} * 100$$

Important

If the mains voltage has an unbalance of above 3%, contact the company, which distributes the electrical energy. If the unit functions with a **unit voltage unbalance between the phases of above 3% the guarantee is invalid.**

6. WATER CONNECTIONS FOR AIR-WATER AND WATER-WATER UNIT

6.1 EVAPORATOR

The connection tubes have to be supported adequately in order that their weight does not damage the plant. The following parts have to be installed on the water circuit of the evaporator:

- Two pressure gauges of adequate scale (in and out of the unit)
- Two shock-absorbing joints (in and out of the unit)
- One shut off valve (normal one in input)
- One setting valve (in output)
- Two thermometers (in and out)
- One circulation pump
- One safety valve on the water buffer
- One automatic air vent valve
- One expansion tank
- An inlet filter placed as near as possible to the evaporator flange
- One flow switch

The above-mentioned installation indications represent necessary conditions for the guarantee to be valid.

Trane is at your disposal to examine any different requirements, which have to be approved before starting up the chiller.

It is necessary that the water flow rate to the unit is compatible with the evaporator one. It is also necessary that the water flow rate is kept uniform while the unit is running: it is suggested to use always a pump system dedicated to the unit and independent from the remaining part of the plant.

Before stalling units with temperature around 0°C please evacuate the exchanger with compressed air in order to avoid breakings due to ice.

6.1A Heat recovery – Desuperheater

The heat exchanger piping must have the same installation features suggested for the evaporator, both for items to fit along the line and for information regarding the water flow rate and the plant water content. (See 6.1c)

6.1B Condenser

Condenser piping must follow the same installation features for the evaporator.

Condensing temperature and water flow rate have to be in accordance with nominal values, unless the acknowledgement order shows different indications. It is strictly necessary that in the presence of condenser side dirty or aggressive water, an intermediate heat exchanger must be installed before the chiller condenser.

The above mentioned installation suggestions represent the necessary condition to keep warranty validity.

6.1C Calculation of minimum water content and flow rates

To grant a perfect running, the machine needs a water content achievable using the following formula:

CHILLER: OPTIMAL $V=P/14DT$

MINIMUM $V=P/35DT$

HEAT PUMP

OPTIMAL $V=P/7DT$
MINIMUM $V=P/20DT$

P = COOLING (HEATING) CAPACITY OF CHILLER (HEAT PUMP) IN KW
DT = DIFFERENTIAL SET ON MICROPROCESSOR
V = MINIMUM WATER CONTENT IN CM

The permitted tolerance for flow rates is equal to 10% of the nominal

6.2 WATER CIRCUIT REGULATION EQUIPMENT

Centrifugal motor pump block

Assures the discharge and the prevalence necessary to supply tube nest evaporator, the tank and the utility.

Automatic filling unit

Assures the water pressure in the plant is maintained at least 1.5 bar, automatically resetting it when necessary.

Safety valve

Takes care of opening the plant in atmosphere if the pressure exceeds the value of 6 bar.

Expansion tank

Takes care of compensating small water hammering and variations of volume for different temperatures.

Check valves

Take care of intercepting the pump for possible maintenance.

6.3 HYDRAULIC DIAGRAM

6.3.1 Hydraulic diagram for units without water tank

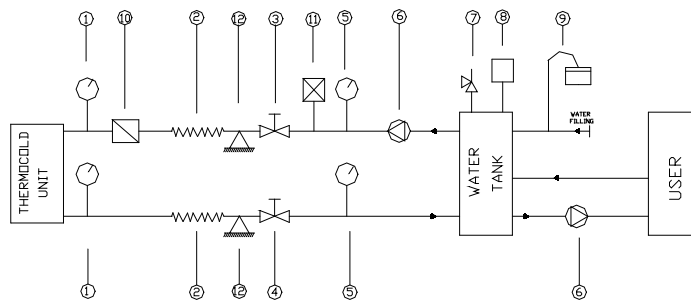

1) Pressure gauges - 2) Shock-absorbing joint - 3) Check valve - 4) Calibration valve - 5) Thermometer - 6) Water pump - 7) Safety valve - 8) Filling group - 9) Expansion tank - 10) Filter - 11) Flow switch - 12) Fixed points

6.3.2 Hydraulic diagram for units with water tank (SE version)

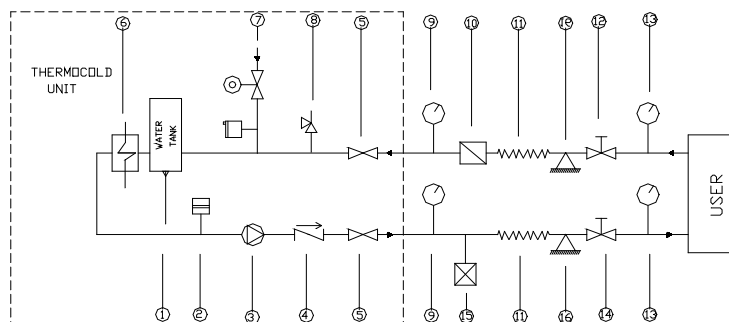

1) Water drain - 2) Expansion tank - 3) Water pump - 4) Check valve - 5) Shut off valve - 6) Evaporator - 7) Filling group - 8) Safety valve - 9) Pressure gauges - 10) Filter* - 11) Shock-absorbing joint - 12) Calibration valve - 13) Thermometer - 14) Interception valve - 15) flow switch - 16) Fixed points

*) Water strainer with meshes not over 2 mm for shell and tube heatexchanger and not over 0.6mm for plated heatexchanger.

The water strainer is obligatory in order to keep the warranty.

6.3.3 SUGGESTIONS FOR THE DESIGN OF THE HYDRAULIC CIRCUIT FOR CONNECTIONS TO UNITS TYPE "QUATTRO"

In case of situations where units "Quattro" are foreseen to work with low outdoor temperatures and it is not requested the production of chilled water, should it be necessary the defrost, it is right to arrange a solution to avoid that the chilled side water tank could reach very low temperatures.

Such a system could be obtained by means of an electric heater or a water system to mix the water produced from the hot side.

7. AERAILIC CONNECTIONS

7.1 DUCTS CONNECTION FOR AIR – AIR UNITS

It is strictly required to provide on the discharge side a kind of ducts whose pressure drops are equivalent to the unit's project values.

Ducts connection must be realised by placing in the way an antivibration joint in impermeable cloth:

This procedure has to be followed in order to cut off any vibration transmission from the unit to the ducts.

Heatexchanger suction and discharge air ducts project and construction must be followed with maximum care in order to avoid air flow restrictions and limitations; such conditions could give rise to a defective running situation.

Hereafter please find a few suggestions for a correct outdoor unit installation:

- 1) Heatexchanger suction and discharge air ducts must be as shortest and straightest as possible.
- 2) The grilles installed on the external suction air must be projected and constructed to offer the lowest resistance to the airflow.
- 3) Right adjustments have to be applied to avoid mixing the heat exchanger suction and discharging air. Discharge side must always be upon any air suction. Possibly the discharge should be upside directed.
- 4) The air through the heat exchanger must not be taken in proximity to heat sources (condensers, conditioners that discharge hot air from kitchens etc.).
It is absolutely to avoid taking hot air from the kitchen cause the high percentage of fat, which would get the coils dirty very quickly.
- 5) The inlet airside must not be directed towards dusty areas.
- 6) The ducts must be leaning to outside to ensure the rain water drainage.
- 7) The inlet air duct must be equipped with a removable panel inside, in order to inspect the coil and to allow periodical clean up.
- 8) The inlet air grilles must be selected to give the lowest possible resistance to the air flow and must be enough strong to prevent the fins deformation and crushing from air flow taking place: fins deformation could obstruct the airflow.
- 9) In case the grille length exceeds 70-80 cm, a stiffening comb must be provided.
- 10) Behind the grille must be installed nets to prevent birds, rats or foreign body in general entrance.

To allow easy maintenance operations, it is suggested to install the units keeping free the followings spaces:

- a) on the left side of the unit (front sight- horizontal discharge), must be left one meter free to allow the following operations:
 - filter replacement;
 - Inspection of the direct expansion exchanger and expansion valve.
- b) on the opposite side of point a), must be left 70 cm free to allow the following operations:
 - Maintenance, possible fan engine stripping down, belt and air flow adjustments.
 - Hydraulic connection to the drain pan.
 - Motor power connections.

7.2 DUCTS CONNECTION TO THE INDOOR UNIT FOR AIR – AIR UNITS

The ducts sizing must take care of the unit nominal air flow. The connection of the air-handling unit to the ducts network must be always done through an antivibration joint. It is suggested to avoid providing diffusion ducts at a distance less than one meter from the discharge fan. In case of ducts too short, in order to ensure the possible fan noise absorption, a kind of baffle can be installed on the duct bend. In this situation it is also suggested to internally insulate the ducts with glass wool or other suited materials. The unit is provided with flange on the discharge side, which allows, by using self-cutting screws, to connect the antivibration joint.

Ducts and diffusion network will be to installer care.

7.3 CONDENSE DRAIN CONNECTION FOR AIR – AIR UNITS

All outdoor and indoor units are equipped with drain pan fitted beneath the exchange coil.

The drain connection on both fronts is 1" female gas.

The drain line to provide must have the same connection diameter and around a 3% grade in the airflow direction.

On the joint proximity, it is necessary to put a siphon of equal height of the fans head pressure, in order to avoid the obstacle to the normal condensing drain and the suction of bad smell that could be easily passed on the ambient.

8. START-UP PRELIMINARY PROCEDURES

8.1 STARTING CHECK

Before starting the unit, even only momentarily, all the machinery supplied by the chilled water, like the air handling units, pumps, etc. have to be checked. The pump auxiliary contacts and the flow switch have to be connected to the control panel as indicated in the electrical diagram. Before carrying out interventions on the valve regulations, loosen the relevant valve gland. Open the discharge valve of the compressor. Open the liquid shutoff valve placed on the liquid line. Measure the suction pressure. If it is lower than 0.42 MPa jumper and strain the solenoid valve on the liquid line. Bring the suction pressure to 0.45 MPa, then remove the jumper. Charge all the water circuit progressively. Starts up the water pump of the evaporator with the calibration valve shut and then slowly open it.

Discharge the air from the high points of the water circuit and check the direction of the water flow. Carry out calibration of the flow by using a measurer (if present or available) or by means of a combination of the readings of the manometers and the thermometers. In the starting phase calibrate the valve on the pressure difference read on the manometers, carry out drainage of the tubes and then carry out fine calibration on the temperature difference between the water in and the water out. The regulation is calibrated in the factory for water in to the evaporator at 12°C and water out at 7°C. With the general switch open, check that the electrical connections are tightly clamped. Check for any possible refrigerant leaks. Check that the electrical data on the label correspond to those of the mains supply. Check that the thermal charge available is appropriate for starting.

8.2 REFRIGERANT SEALS CONTROL

Trane units are sent with the complete charge of refrigerant and are at a sufficient pressure to check the seal after installing. If the system were not under pressure, blow refrigerants (vapour) into it until pressure is reached and look for leakage.

After having eliminated the leakage, the system has to be dehydrated with a vacuum pump up to at least 1mm Hg - absolute pressure (1 Torr o 133.3 Pa). This is the minimum recommended value to dehydrate the plant.

Dangers do not use the compressor to vacuum the system.

8.3 REFRIGERANT CHARGE CHECK

Trane units are supplied with a complete charge of refrigerant. If bubbles can be seen through the peephole with the compressor running with a full charge and steadily, it means that the refrigerant charge is insufficient.

Danger While refrigerant is being added do not exclude any control system and let the water circulate in the evaporator to avoid the formation of ice.

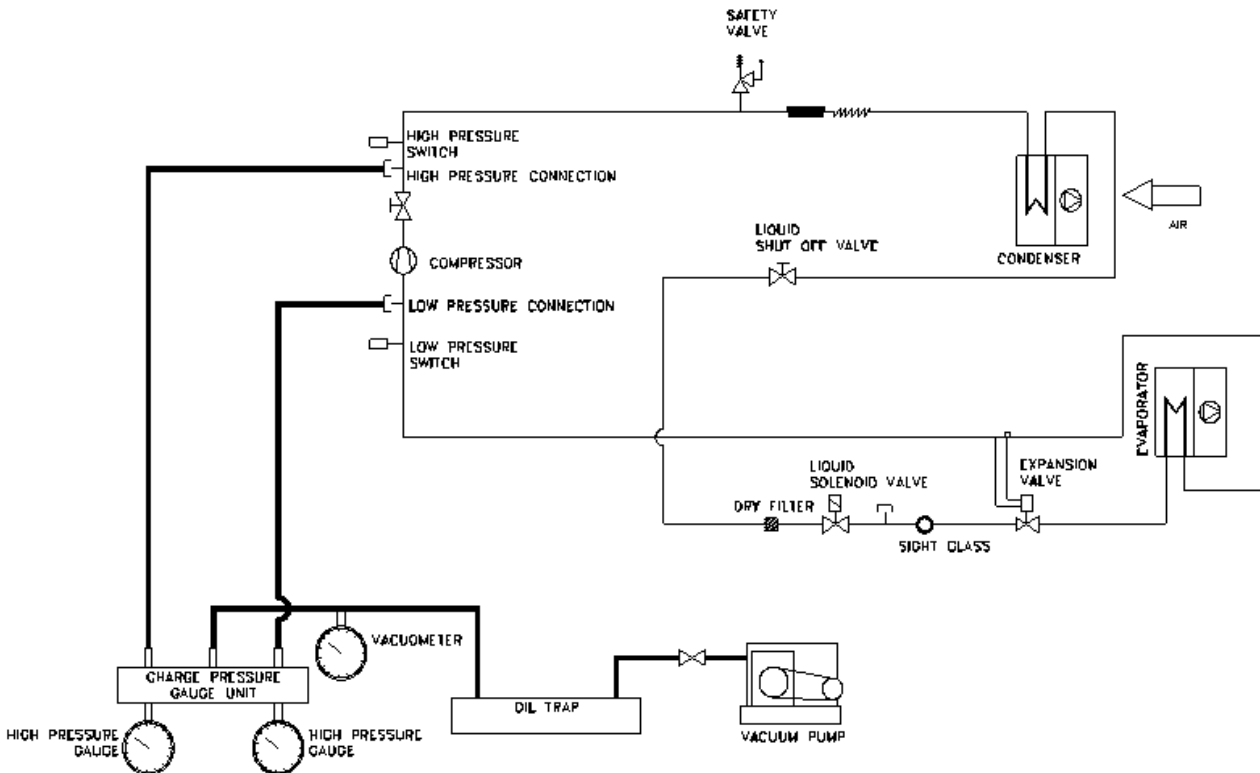

Cooling circuit diagram with connection to vacuum pump

8.4 REFRIGERANT CHARGE

8.4.1 Charge with unit stopped and in vacuum (refrigerant charge in the liquid phase)

Open the shut off valve as far as possible so that it closes the service coupling. Connect the refrigerant cylinder to the service coupling without tightening the coupling. Half close the liquid shut off valve. If the circuit has been dehydrated and is in vacuum, charge the liquid by turning the cylinder upside down. Weigh and charge the appropriate quantity. Open the valve completely. Start up the unit and leave it running at full charge for some minutes. Check that the indicator is clear with no bubbles. Make sure that the transparency condition without bubbles is due to the liquid and not to the vapour. Correct functioning of the unit allows for overheating of 4 - 7° C and subcooling of 4 - 8°C. Values of overheating which are too high may be caused by a lack of refrigerant, whereas high subcooling values may mean an excess of charge.

After intervention on the charge, it is appropriate to check that the unit runs within the declared values: with unit steadily running on a full charge, measure the temperature of the suction line downstream of the thermostatic valve bulb; read the balance pressure to the evaporator on the low pressure manometer and the corresponding saturation temperature.

Overheating is equal to the difference between the temperatures measured in this way. Then measure the temperature of the liquid line coming out of the condenser and read the balance pressure to the condenser on the high-pressure manometer and the corresponding saturation temperature. The subcooling is the difference between these temperatures.

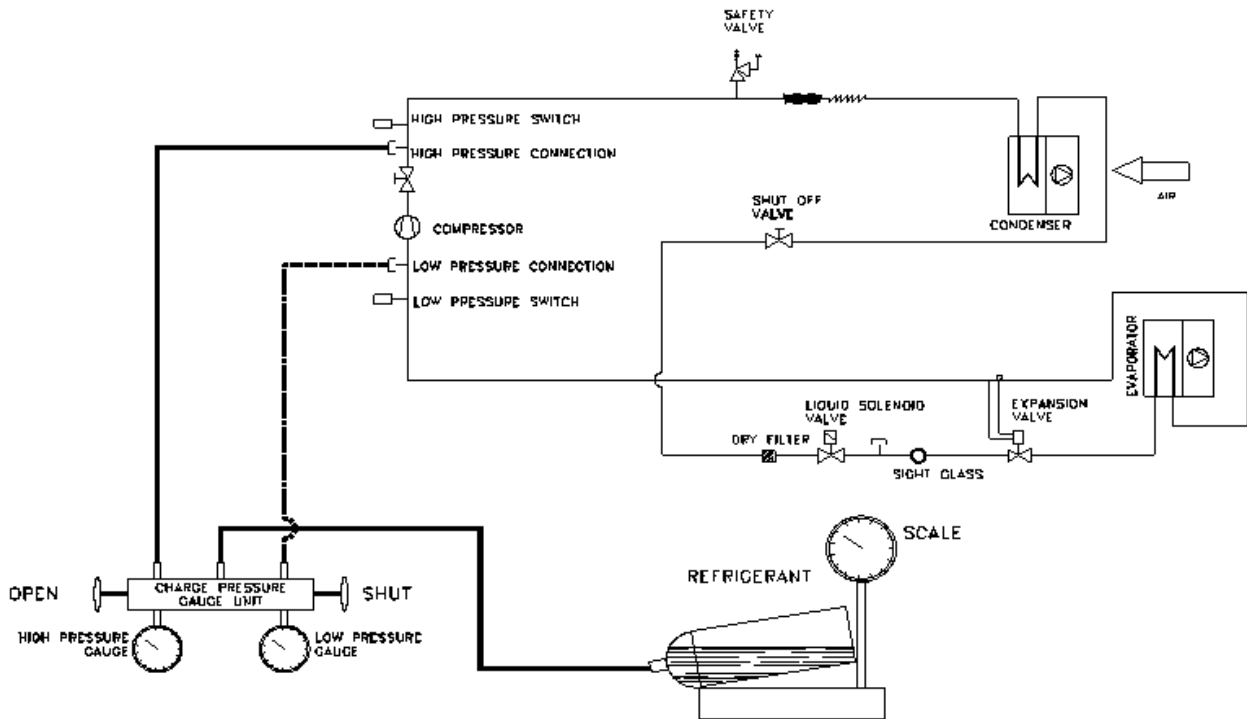

8.4.2 Refrigerant charge addition with the unit running (refrigerant charge in the vapour phase)

Warning charge vapour only. Do not charge liquid because it may damage the compressor.

Connect the refrigerant cylinder to the service valve without tightening the coupling. Drain the connection piping and tighten the coupling. Charge each circuit until the indicator indicates liquid without bubbles. Now the unit has the required charge. Make sure not to over charge the circuit. Charging more than necessary leads to a higher delivery pressure, greater power consumption and possible damage to the compressor.

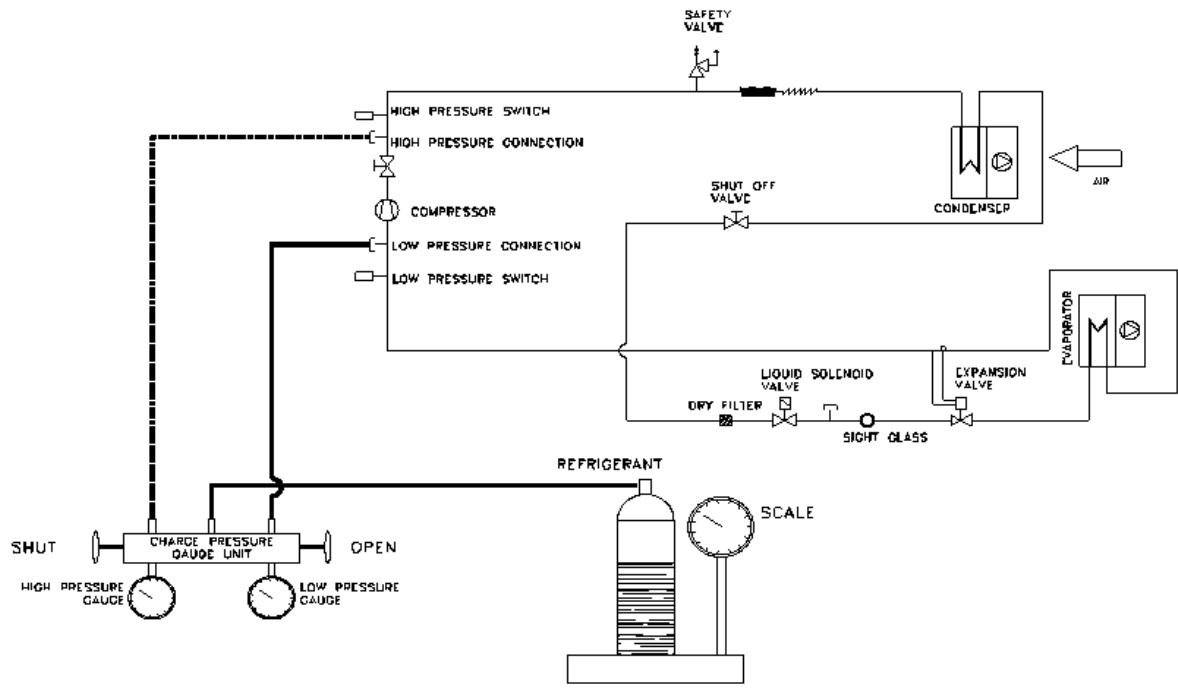

Charge in vapour phase

9. START-UP

9.1 PRELIMINARY CONTROLS

Before starting up the equipment it is very important to check that all the operations described in the paragraph "SETTING FOR START UP" have been carried out correctly.

Moreover check that all the mechanical and electric equipment has been tightened perfectly. Particular attention should be paid to the main components (compressor, exchangers, ventilators, electrical motors, and pump) if loose fastenings are found tighten them well before starting up the machine.

The oil heaters have to be inserted at least 8 hours before starting up. Ensure that the compressors' carter is hot. Open the compressor valve and the cooling circuit one, which may have been shut for charging. Control all the machinery connected to the unit.

9.2 STARTING UP

Start up the unit by pressing the ON/OFF button. About 20 seconds pass from the moment in which the start up request of the unit is given to the moment in which the (first) compressor starts. Three hundred and sixty seconds will pass from the last shut down to the next start up of the same compressor.

Check the rotation direction of the fans and rotative compressors. If it is not the right one, invert two supply phases. Ensure that all the safety and control equipment is functioning correctly. Control the temperature of the water coming out of the evaporator and regulate the control setting if necessary. Control the oil level.

9.3 WARM UP OF THE PLANT FOR UNITS AIR TO WATER AND WATER TO WATER

In order to keep all the machine components in good condition and to optimise their use, during the warm up it is necessary to bring the circuit to the right temperature before releasing cooling energy to the utilities.

The following steps must be followed for this to be carried out:

- * start up the machine
- * wait for the water in temperature to reach the running temperature
- * start up the consumers

Follow the above mentioned procedure every time the plant is stopped long enough for the water temperature contained in it to rise.

9.3a Warm up for air to air units

Once the units have been installed, ducts connection, electrical connections (with the relevant electric panel) carried out, the following steps must be followed to start up the unit:

- 1) After making sure that the general switch has been connected (as suggested on the label put on the electric panel), switch on the unit through the thermostat in the requested mode, switching on the electric panel fan.
- 2) Check the fan rotation direction and in case reverse the phases on terminals inside the electric panel.
- 3) Set the thermostat to the required temperature, which has to be lower than the ambient one in summer mode. In this position, the compressor and the outdoor unit fan motor start running; check the fan rotation direction and if it is necessary all the operations concerning the inversion of the phases have to be repeated. Starting from this moment, while the air handling unit fan will be continuously running, the outdoor unit will run or will stop according to the thermostat needs.
- 4) Once the unit has been started, it is suggested to check that current absorption values are within the limits shown into electrical data.

9.4 CONTROL OF THE OIL CHARGE

All the compressors mounted on Trane units are factory charged with oil whose chemical characteristic of stability are very good, so it is not necessary to change frequently the lubricant oil.

In case of burns for the electrical motor or fault of the compressor, it is necessary to make a test to check the acidity of the lubricant oil and, eventually, clean the circuit to reduce the acidity to correct values, mounting for instance an antiacid filter and changing the oil in the circuit.

Semi-hermetic reciprocating compressors

When the oil differential pressure cut off switch intervenes, connect a pressure gauge to the Schrader valve available on the compressor in correspondence to the pressure cut off switch connection on the oil pump discharge. With compressor running, read the pressure on this pressure gauge and the one on the refrigerant low pressure gauge. If the difference between the two readings is lower than 0.07 MPa and if the oil is not visible on the indicator, lubricant must be added, after having checked that it did not end up in the refrigerant circuit due to a functioning anomaly. In order to carry out an addition of oil, close the liquid shut off valve and wait for the pressure in the compressor to fall to 0.015 MPa relative, by

short-circuiting the low pressure cut off switch. Wait for a few minutes and repeat the operation as many times as is necessary to bring the pressure down to 0.015 MPa. The normal water flow to the evaporator must be assured during the operation. Close the compressor discharge valve. Connect the Schrader valve placed in correspondence to the carter near the oil indicator using a flexible tube to a hand pump immersed in the oil container. Add the necessary quantity of oil, being careful not to allow foreign bodies or air into the compressor. Disconnect the flexible tube. Perform a vacuum on the compressor. Open the shut off valves. Remove the short circuit form the low pressure cut off switch. Start up the compressor once again. Let it run for 20 minutes on a full charge and check the oil level. Using this procedure at 0.015 MPa, a small quantity of refrigerant gets into the oil. During the addition of the oil the refrigerant escapes into the atmosphere, blocking the entry of air into the compressor. If the carter shows no pressure ($\cong 0,015$ MPa), once oil charging has finished, it will be necessary to vacuum the compressor once again by means of a service connection. When oil charging has to be completed or repeated, we recommend using only approved quality oil.

Screw compressors

WARNING: the oil into the carter has discharge pressure.

The oil circulation is due to differential pressure; The minimum oil flow, because the oil still has his lubricant function and screw seal, is ensured when the compressor is working into the right limits. During the start up it is admitted, for few seconds, that the compressor run without oil but, after 20 seconds from the start up the differential pressure must be at least 6 bar, otherwise the compressor is stopped from the microprocessor.

The units equipped with Refcomp compressors, are equipped with a further safety. In fact it is mounted a differential pressure switch on the oil filter whose set is 3,5 bar. If the pressure drop through is higher than this value it means that the filter is dirty and must be changed.

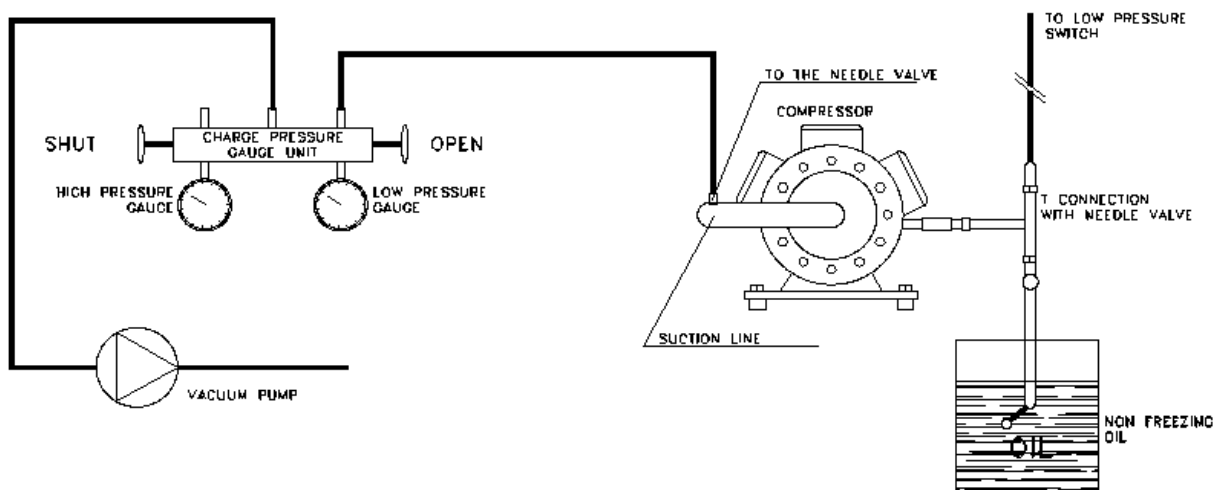

9.5 POWER SUPPLY TO THE AUXILIARY CIRCUIT

The power supply to the auxiliary circuit is 220V for all the units. Connection to the power circuit is inside the panel and is carried out in the factory. The compressor oil heaters, the protections against compressor over temperature and the cooling water safety indicator are connected so as to always be operative, as long as the electrical panel is power supplied.

10 MAINTENANCE

Maintenance operations are fundamental in order to keep the units running properly, both purely functional and energetically points of view.

Every Trane unit comes with a logbook, in which the user or the person delegated to machine maintenance can keep all the required notes, in order to keep a historical log of the Trane unit.

A lack of notes in the logbook could be considered proof of careless maintenance.

10.1 SIGHT CHECK OF THE UNDER PRESSURE VESSELS STATE

The risks due to the pressure inside the circuit have been eliminated or (when it is not possible) reduced by means of safety devices. It is important to check periodically the status of these devices and to carry out the components inspections and replacement as follows.

Check at least once per year the under pressure vessels state.

It is important to check that the surface does not get rusty and that neither corrosion nor deformations are visible.

In case the superficial oxidation and the corrosion are not properly controlled and stopped in time, cause a thickness reduction with a consequent reduction of the vessel mechanical resistance.

Use antioxidant paint or products to protect.

Description of the operations	Recommended frequency
Control of compressor oil level	monthly
Control of the suction temperature (superheating)	monthly
Control of the hydraulic circuit water filling	monthly
Control of electric absorption fan motors and compressor	monthly
Control of power supply and auxiliary power	monthly
Control of refrigerant charge through liquid sight glass	monthly
Control of the state of the carter electric heaters	monthly
Carrying out tightening of all the electrical connections	monthly
coil cleaning	seasonal
Control of the functioning of the compressor solenoid valves and liquid line	seasonal
Control of the setting of the regulation and safety thermostat	seasonal
Control of the state of the fan and compressor contactors	seasonal
Functional test of the evaporator heater	seasonal
Noise control of the engine and fan bearings	weekly
Pressure tank state checking	yearly
Cleaness control for coils and air-filters	weekly

Further operations for units with centrifugal fans

Control of the cleanliness of the discharge and circulation ducts	yearly
Control of the correct functioning of possible dampers or inlets	seasonal
Control of the lubrication of the shaft bearings	seasonal
Control of the pulley - engine and pulley - fan alignment	seasonal
Control of the tension of the transmission belts; if they are excessively worn they should be replaced	seasonal
Check that the rotor is centred on the shaft and that it does not touch the Archimedean screw	seasonal
Control of cleaning if necessary of the fan rotor and Archimedean screw	seasonal
Control and if necessary tightening of the blocking screws of the engine pulley	seasonal
Control of the presence of excessive or unusual vibrations	seasonal
Control of the fan joint seal - outlet	seasonal
Control of the current absorption of the three engine phases	seasonal

11. RECOMMENDED SPARE PARTS

There follows a list of the recommended parts for several years' running. Trane is at your disposal to recommend a personalised list of accessories according to the commissioned order, including the part number of the equipment.

1 year	
Components	Quantity
fuses	(all)
filter dryers	(all)
solenoid valves	(1 per type)
thermostatic valves	(1 per type)
pressostats	(1 per type)
pressure gauges	(1 per type)
contactors and relays	(1 per type)
thermal protectors	(1 per type)
carter electric heaters	(1 per type)
4-way valve	(1 per type)
check valve	(1 per type)
safety valve	(1 per type)
sight glass	(1 per type)
fans and engines	(1 per type)

2 year	
Components	Quantity
fuses	(all)
filter dryers	(all)
solenoid valves	(all)
thermostatic valves	(all)
pressostats	(all)
pressure gauges	(all)
contactors and relays	(all)
thermal protectors	(all)
carter electric heaters	(all)
4-way valve	(1 per type)
check valve	(1 per type)
safety valve	(1 per type)
sight glass	(1 per type)
fans and engines	(1 per type)
electrical components	(all)
compressors	(1 per type)

5 year	
Components	Quantity
fuses	(all)
filter dryers	(all)
solenoid valves	(all)
thermostatic valves	(all)
pressostats	(all)
pressure gauges	(all)
contactors and relays	(all)
thermal protectors	(all)
carter electric heaters	(all)
4-way valve	(all)
check valve	(all)
safety valve	(all)
sight glass	(all)
fans and engines	(all)
electrical components	(all)
compressors	(all)
heatexchanger	(1 per type)

12. IMPROPER USES

The unit is projected and built up to grant the maximum safety in its proximity, as well as to resist to the aggressive environmental conditions. The fans are protected by grilles.
Residual risks are indicated with warning labels.

SAFETY SYMBOLS



DANGER:
General danger

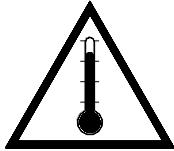

DANGER:
Temperature

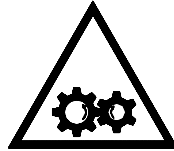

DANGER:
Moving parts

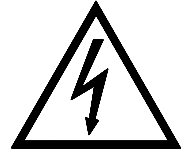

DANGER:
Cutoff voltage



Trane optimizes the performance of homes and buildings around the world. A business of Ingersoll Rand, the leader in creating and sustaining safe, comfortable and energy efficient environments, Trane offers a broad portfolio of advanced controls and HVAC systems, comprehensive building services, and parts. For more information, visit www.Trane.com.

Trane has a policy of continuous product and product data improvement and reserves the right to change design and specifications without notice.

© 2016 Trane All rights reserved
CG-SVX035A-GB April 2016

